



GC6170

HIGH SPEED LOCKSTITCH SEWING MACHINE WITH
VERTICAL EDGE TRIMMER
INSTRUCTION BOOK
PARTS CATALOGUE

XI'AN TYPICAL INDUSTRIES CO., LTD.

※NOTE (Fig. 1)

Before putting a new machine into operation, run-in operation is required for a new machine. Remove the rubber plug (A) on the top arm and drip a little oil, then remove the rubber plug (B) and replenish sufficient amount of oil, then lift the presser foot and run the machine at a low speed of 3000 spm to check oil distributing condition. When lubricating is normal, keep the machine run in at this speed for about one month to run-in operation completely.

knife components lubrication: Apply 1 or 2 drops of oil at C every time as illustrated, four times everyday.

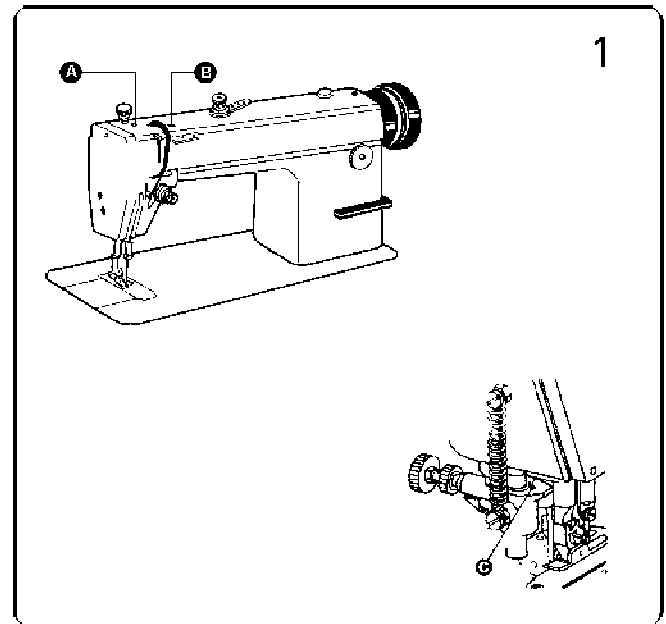

1. OIL FILLING (Fig. 2)

(1) The oil amount in the oil reservoir is controlled through the reference marks A and B shown in Fig. 2. The mark A indicates the max oil amount level, the mark B for the min. oil amount level. If the oil amount level is under the mark B replenish the oil reservoir with oil in time.

(2) When filling oil, loosen the oil draining screw (c), drain off the remaining oil in the oil reservoir completely, clean the oil reservoir and tighten the oil draining screw (c), then fill the oil reservoir with fresh oil.

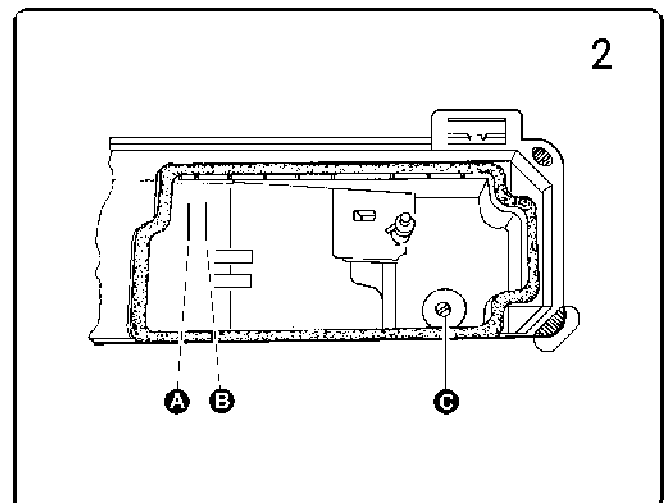

2. ROTATING HOOK OIL AMOUNT ADJUSTMENT (Fig. 3)

Adjust the oil amount of the rotating hook by turning the oil amount adjusting screw (A). Turn the screw (A) clockwise (in the "+" direction) to increase the oil amount; turn it counter-clockwise (in the "-" direction) to decrease the oil amount.

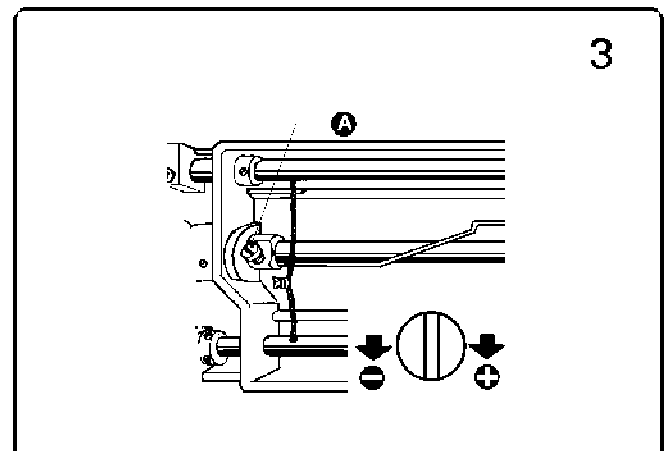

3. OIL PUMP ADJUSTMENT (Fig. 4)

In ordinary operation, adjustment is not required for the oil pump. If oil splashing does not occur in the oil check window when the machine runs at a low speed, close the clearance of the bypass oil hole.

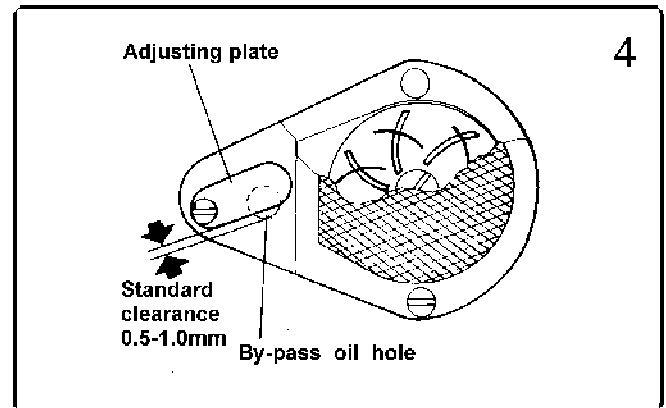

4. NEEDLE INSTALLATION (Fig. 5)

Turning the balance wheel to lift the needle bar to the upper end of its stroke. Loosen the needle clamp screw while keeping the long groove of the needle leftward, fully insert the needle shank up to the bottom of the needle socket, then tighten the needle clamp screw.

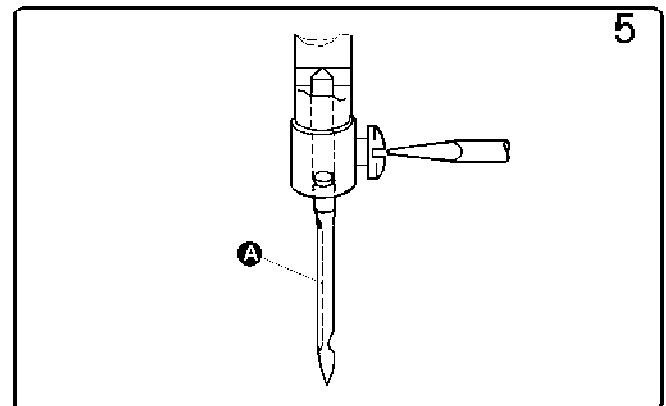

5. CONNECTION OF THE CLUTCH LEVER WITH THE PEDAL (Fig. 6)

(1) The optimum tilt angle of pedal is approximately 15 deg.

(2) Adjust the clutch so that the clutch lever (c) align with the draw bar (B) as shown in Fig. 6

(3) The machine pulley should rotate counter clockwise when viewed from the outside of it. The rotating direction of motor pulley can be reversed by turning the plug of the motor at 180 deg.

(4) Adjust the tension of O-Belt (F) by moving the motor up and down, the proper tension of the O-belt is a slack of 10-20 mm when the belt is depressed at the center of the belt by finger.

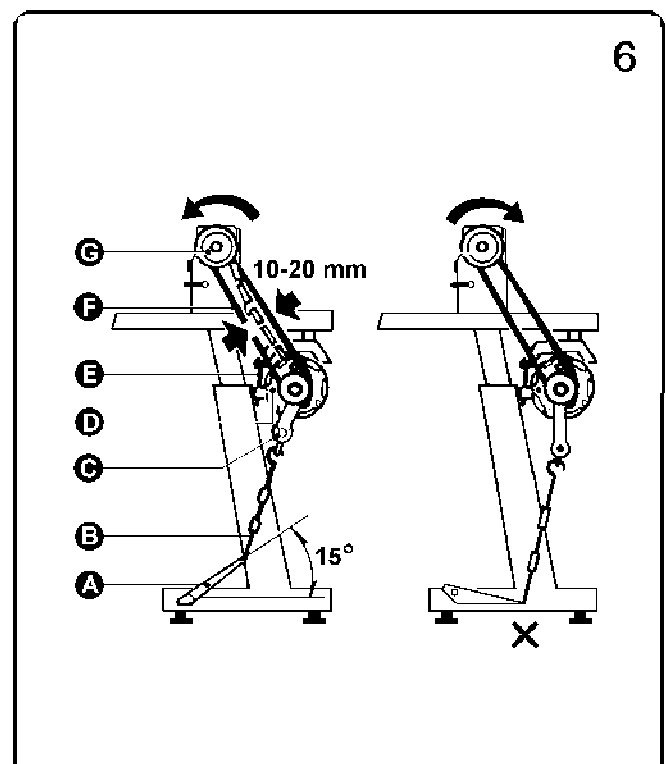

6. BELT COVER INSTALLATION (Fig. 7)

Install the belt cover for the sake of safety.

Install belt cover (C) to arm with screw (A) and screw (B), and install belt cover (E) on board with screw (D).

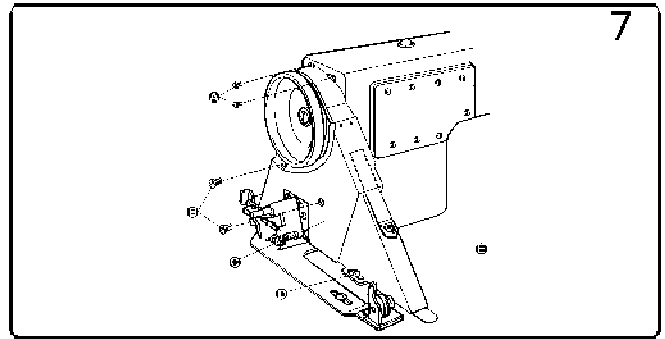

7. ADJUST THE OPENING TIME OF THE TENSION DISCS (Fig. 8)

Within the presser foot lift range, the opening time of the tension discs can be adjusted as follows:

(1) Remove the rubber plug from the back of the arm and Loosen the screw (A) of the knee lift level (left)

(2) Move the tension releasing cam (D) leftward for earlier opening or rightward for Later opening. It will facilitate the adjustment if putting a block under the presser foot lift.

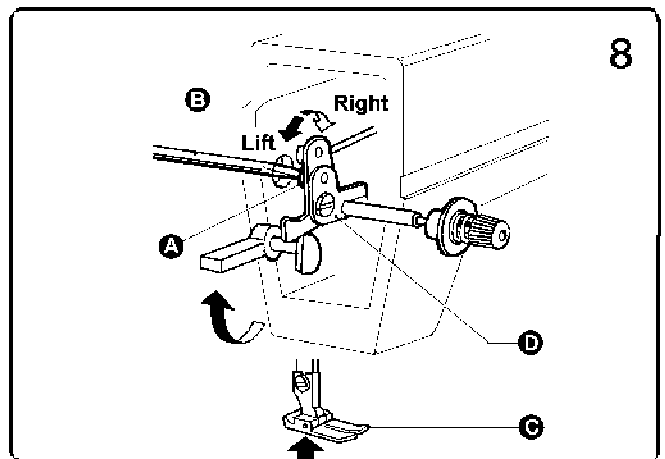

8. THREADING (Fig. 9)

To thread the needle thread, raise the needle bar to the upper end of its stroke, lead the thread from the spool and perform threading as shown in Fig9. To draw the bobbin thread, hold the end of the needle thread and turn the balance wheel to lower the needle bar and then lift it to its highest position. Pull the ends of needle thread and bobbin thread frontward under presser foot.

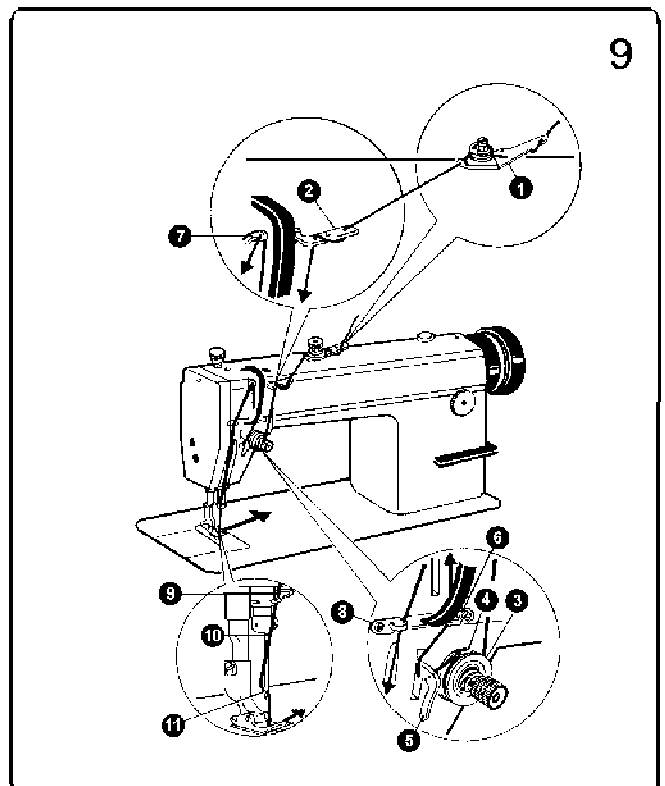

9. WINDING INSTALLATION AND ADJUSTMENT (Fig. 10)

The bobbin winder pulley should align with the V-belt and there should be some clearance between them. When the bobbin winder stop latch lever is depressed, the V-belt should be in touch with the bobbin winder pulley in order that the bobbin winder pulley can be driven by the V-belt.

The thread wound on the bobbin should be neat and tight. If not tight, adjust the winding tension by turning the tension stud nut (A) of the bobbin winder tension bracket, when the thread wound on the bobbin does not present a cylindrical shape as shown in Fig. 10 (a), Loosen the set screw (B) of the bobbin winder tension bracket and move the bracket (C) leftward or rightward, if the thread is wound as shown in the figure (b), move the bracket leftward or rightward of wound as shown in the figure (c), move it leftward. After positioning the bracket adequately, tighten the set screw (B).

Do not overfill the bobbin, The optimum wound length of the thread will fill about 80% of the bobbin capacity. This can be adjusted by the screw (E) of the bobbin winder stop latch.

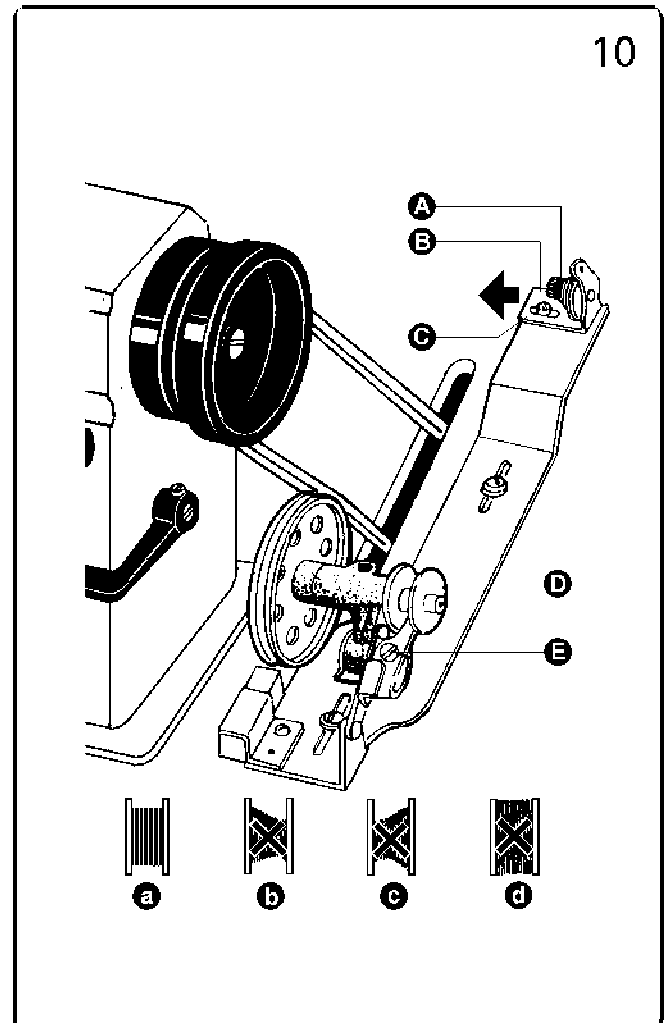

10. ADJUST THE PRESSURE OF PRESSER FOOT (Fig. 11)

Pressure of the presser foot is adjusted in accordance with thickness of materials to be sewn.

First loosen the lock nut (A), for heavy materials, turn the pressure regulating thumb screw as shown in Fig. 11 (a) to increase the pressure, while for light materials, turn the pressure regulating thumb screw as shown in Fig. 11 (b) to decrease the pressure, then tighten the lock nut (A).

The pressure of the presser foot is recommended to be less as long as normal feeding is ensured.

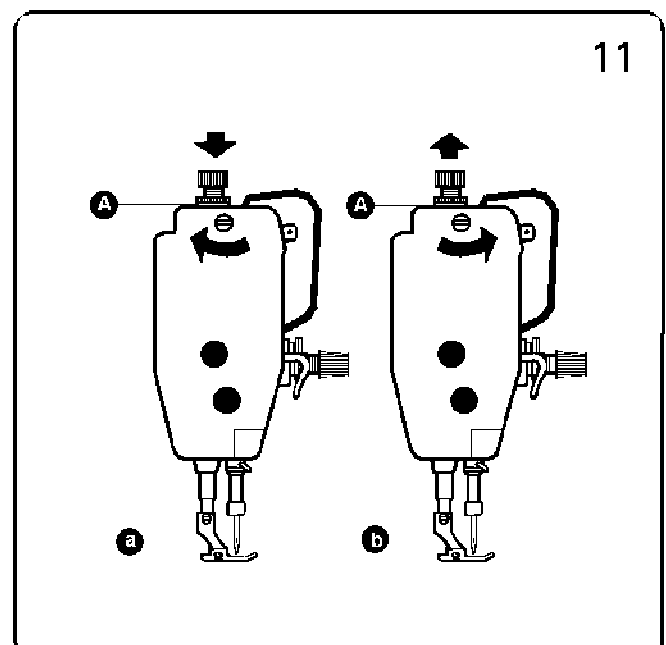

11. THREAD TENSION ADJUSTMENT (Fig. 12, 13, 14)

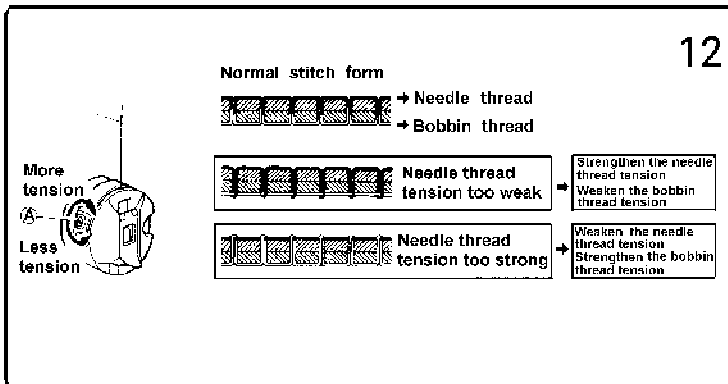

Thread tension should be determined in accordance with the stitch obtained by adjusting the tension of the bobbin thread and needle tension (Fig. 12).

The tension of the bobbin thread: to be adjusted by turning the tension spring regulating screw of the bobbin case. After adjusting, insert the bobbin into the bobbin case and hold the end of the thread from the bobbin case to hang the bobbin case, if the bobbin case falls slowly and evenly, the proper tension of the bobbin thread is obtained.

The tension of needle thread: to be adjusted by turning the thumb nut.

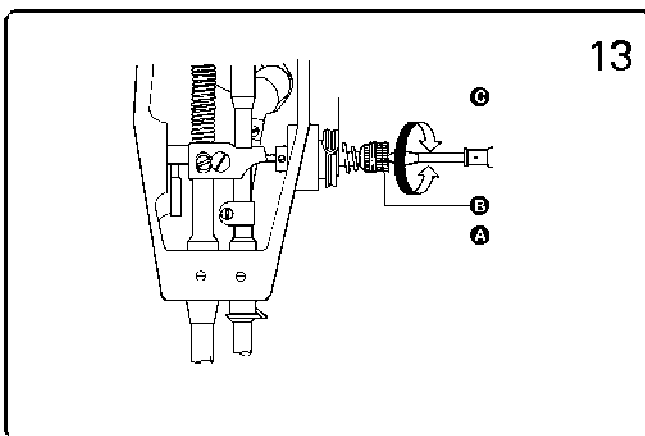

The stroke of the thread take-up spring runs from 8mm to 10mm, when sewing very thin fabrics, reduce the thread take-up spring tension and increase the thread take-up spring stroke, where as increase the thread take-up spring tension and reduce the thread take-up stroke when sewing very thick fabrics.

Adjusting the thread take-up spring tension: (Fig. 13) First loosen the set screw (A), Turn the tension stud (B) counter-clockwise to decrease the tension of the thread take-up spring (C) to zero. then turn the tension stud (B) clockwise till the spring (C) comes to the notch of the tension regulating bushing, and again turn the tension stud (B) halfway back (counter clockwise), After the adjustment, tighten the set screw (A).

Adjusting the thread take-up spring stroke: (Fig. 14) loosen the set screw (B) turn the stud (C) clockwise to increase the stroke or turn stud (C) counter-clockwise to decrease the stroke After the adjustment. tighten the set screw (B).

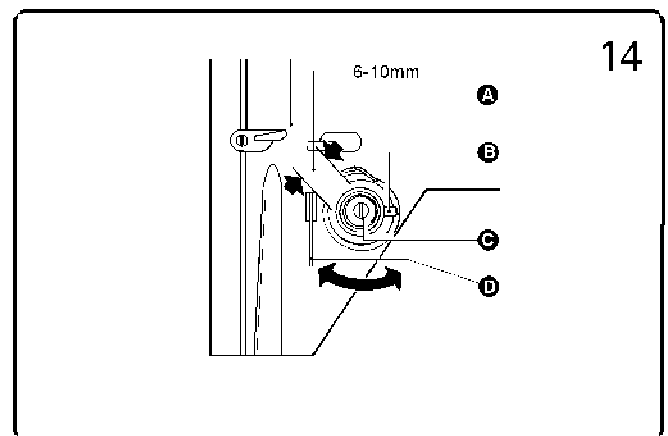

12. ADJUST THE SYNCHRONILATION OF THE NEEDLE WITH ROTATING HOOK (Fig. 15, 16)

When lifting the needle bar from its lowest position of the stroke to the distance 2, the hook point D of the bobbin should align with the center line of the needle and be 1.0-1.5 mm above upper end of the needle eye (Fig. 15)

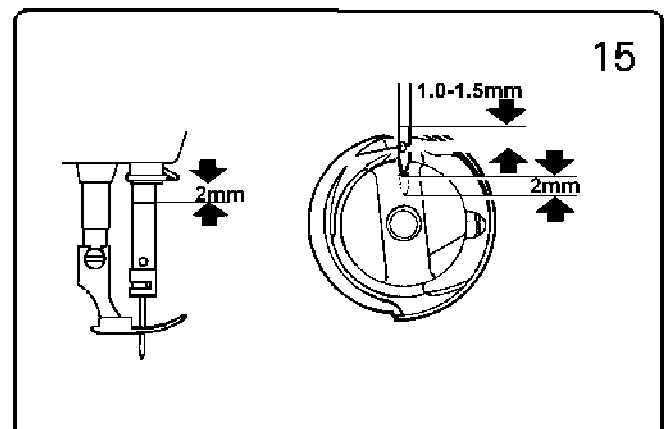

The clearance between the bottom of the needle notch and the hook point should be 0.05 mm (Fig.16).

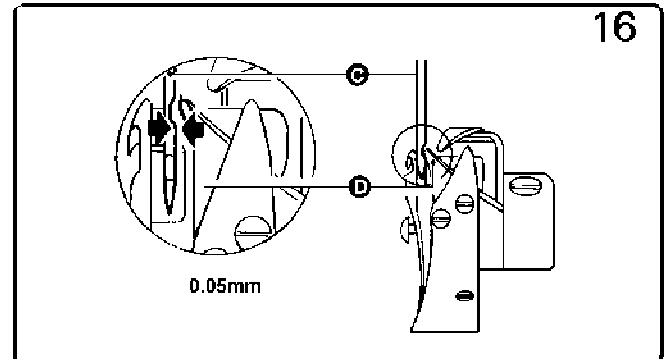

13. ADJUSTMENT OF STITCH LENGTH AND REVERSE FEEDING (Fig. 17)

The stitch length can be adjusted by turning the dial (A). The figures on the face (B) of the dial show the stitch length in mm. the reverser feed lever must be depressed by another while adjusting the stitch length. The reverse feeding starts when the reverse feed lever (c) is depressed, the machine will feed forward again if the reverse feed lever is released.

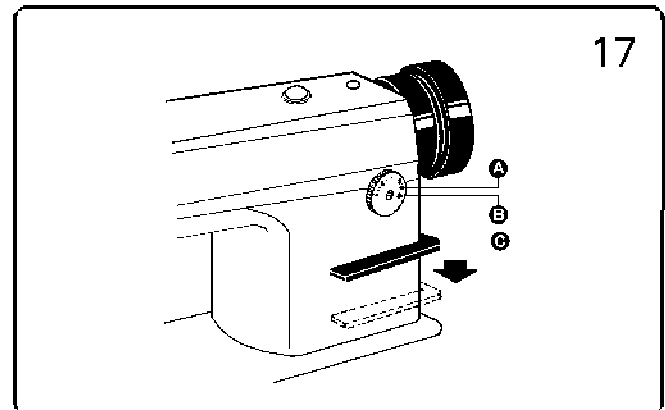

14. ADJUST THE SYNECHRONILATION OF THE NEEDLE MOTION WITH FEED MOTION (Fig. 18, 19)

To adjust the feed dog position (G), first should release the two set screw (F) and turn around the balance wheel by hand. when the needle (A) point reaches the surface of the throat plate (B). the top of the feed dog(C) should be flush with the throat plate surface. After the adjustment . tighten the set screws (F).

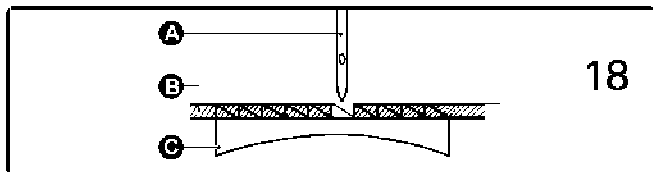
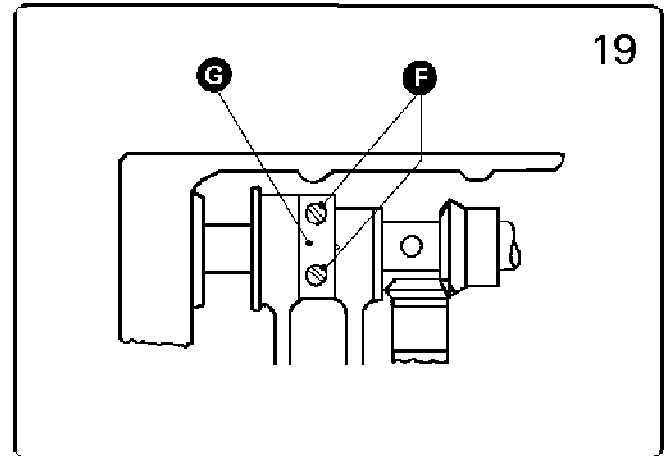

15. STITCH LENGTH ERROR ADJUSTMENT (Fig. 20)

Loosen screw (A) to adjust stitch length adjusting cam(B), Turn it rightward to narrow the stitch length as forward sewing. and widen it as reverse sewing; turn it leftward to widen the stitch length as forward sewing , and narrow it as reverse sewing.

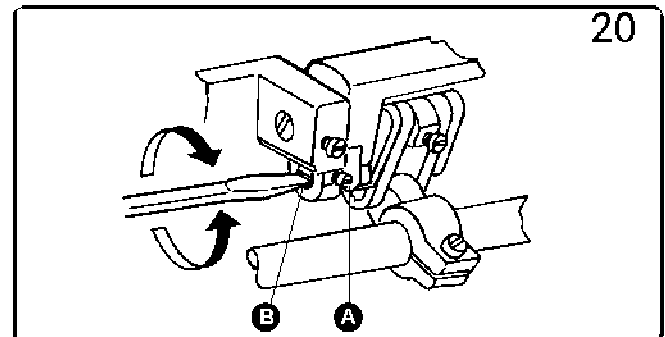

16. FEED DOG HORILONTALLTY ADJUSTMENT (Fig. 21)

Heighten the front of feed dog to prevent fabric from wrinkling, lower the front of feed dog to prevent fabric from defection, breaking of hook thread.

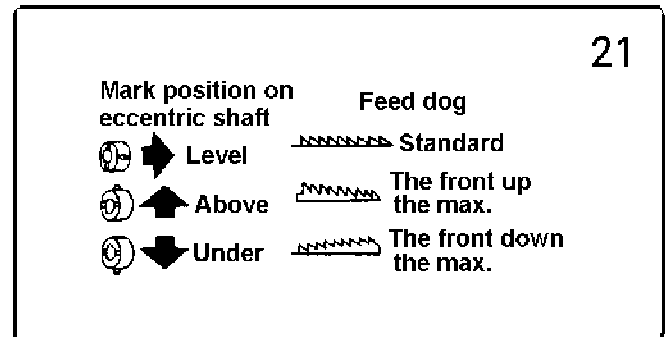

17. THREAD TAKE – UP LEVER OIL SUPPLY ADJUSTMENT (Fig. 22)

Before the machine is carried away from the factory .the thread take –up lever oil supply adjusting pin has already been adjusted in the proper state and the user doesnt need the adjustment. As the oil supply amount of the thread take –up lever is too large or too small. the adjustment is needed.

Adjust as the followings : when the dot mark on the oil adjusting pin is upper position ,the oil is the maximum (Fig. a)

When the dot mark on the oil adjusting pin is the lower position . the oil is the minimum. (Fig. b)

Turn the adjusting pin to a certain degree with a screwdriver to make it reach the necessary oil amount position (Fig. c).

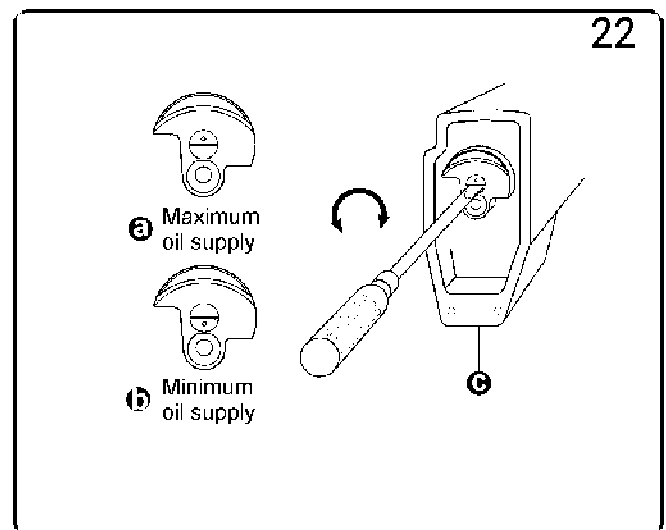

18. ADJUST KNIFE (Fig. 23, 24)









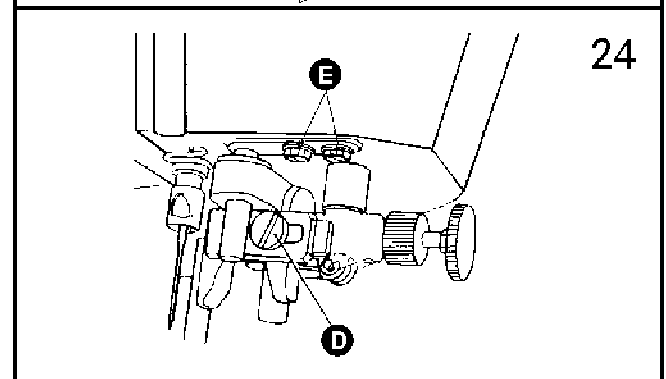
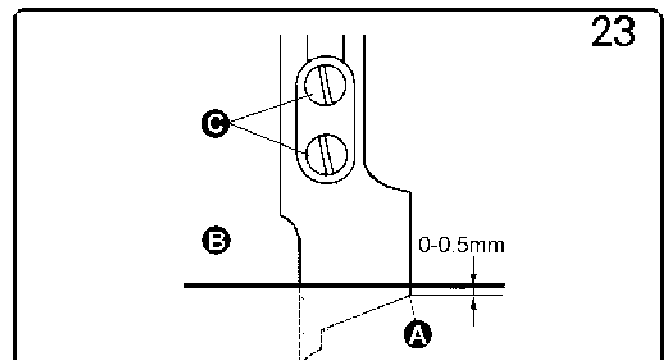

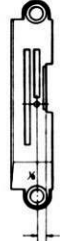

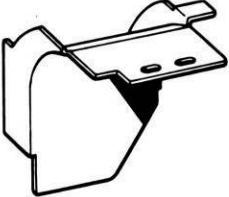
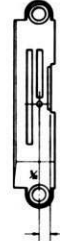
(1) Adjust knife

Adjust knife as illustrated: move knife to the lowest point, Adjust the distance between point A of knife to needle plate B to 0 – 0.5mm, release the screw C for replaing knife.

(2) Adjust trimedge width

The trimedge width depend on the specification of needle plate , when adjust trimedge width release screw D, make knife edge touch the edge of needle plate, Then tighter the screw, Release the screw E to aligne knife edge till knife work well.

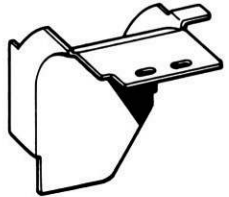

NAME OF PARTS INCH	NEEDLE PLATE	PRESSER FOOT ASSY	FEED DOG	MATERIAL GUIDE
3/32	 <p>029100002 2.4 mm</p>			
1/8	 <p>029100003 3.2 mm</p>	 <p>029701000</p>	 <p>029600001</p>	 <p>029800003</p>
5/32	 <p>029100004 4 mm</p>			
3/16	 <p>029100005 4.8 mm</p>	 <p>029702000</p>		
1/4	 <p>029100006 6.4 mm</p>	 <p>02276</p>		
5/16	 <p>029100007 7.9 mm</p>	 <p>153720000</p>	 <p>029600002</p>	 <p>029800004</p>
3/8	 <p>029100008 9.5 mm</p>			

These parts are optional,additional order required if you need them.

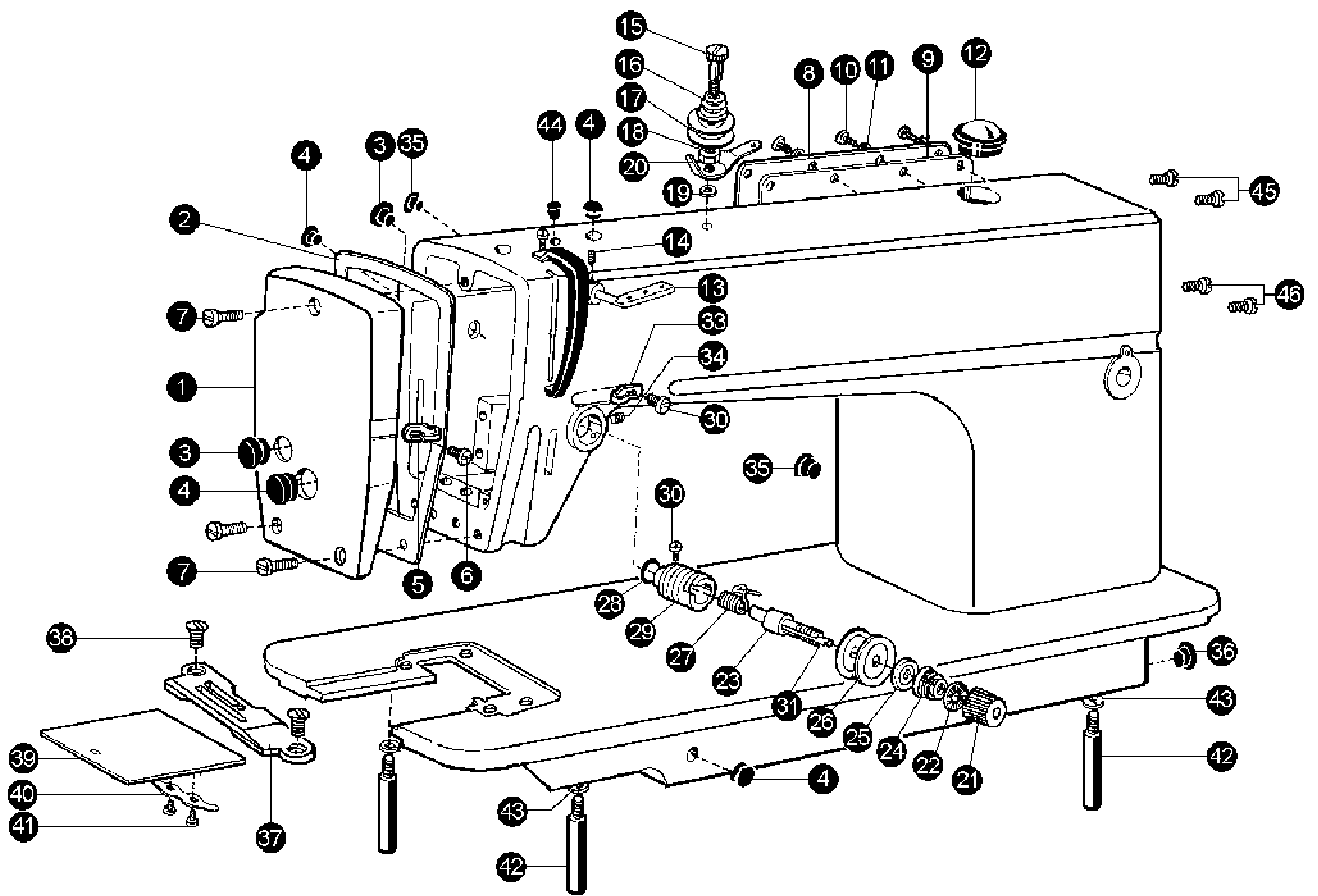

1. ARM BED AND ITS ACCESSORIES

No.	Ref. No.	Description	Qt.
1	124T1 – 002B1	Face plate	1
2	124T1 – 002B2	Gasket for Face plate	1
3	22T1 – 003C3	Rubber plug	2
4	22T1 – 003C4	Rubber plug	4
5	22T1 – 003C5	Thread guide on face plate	1
6	22T1 – 003C6	Thread guide screw	1
7	22T1 – 004	Face plate screw	3
8	22T1 – 005D1	Back plate	1
9	22T1 – 005D2	Gasket for Back plate	1
10	22T1 – 006	Set screw	8
11	22T1 – 007	Washer	8
12	22T1 – 008H	oid check Window	1
13	22T1 – 010	Three hole thread guide	1
14	28T4 – 083	Set screw	1
15	22T1 – 009E1	screw	1
16	22T1 – 009E2	Spring for pre – tension	1
17	22T1 – 009E3	Discs for pre – tension	2
18	22T1 – 009E4	Washer	1
19	GB896 – 86	Spring Washer	1
20	22T1 – 009E5	thread guide for pre – tension	1
21	124T1 – 003C1	Knub for thread tension regulator	1
22	22T1 – 012F10	Thumb nut revdution stoper	1
23	22T1 – 012F1	Thread tension stud	1
24	124T1 – 003C2	Thread tension spring	1
25	22T1 – 012F4	Thread tension releasing disc	1
26	22T1 – 012F5	Thread tension disc	2
27	22T1 – 012F6	Thread take – up spring	1
28	22T1 – 012F11	Rubber ring	1
29	22T1 – 012F7	Thread tension regulating	1
30	22T1 – 012F8	Set screw	1
31	22T1 – 012F9	thread tension releasing pin	1
32	22T1 – 013	Set screw	1
33	22T1 – 014	Thread guide for arm center	1
34	22T1 – 003C6	Set screw	1
35	22T1 – 015	rubber plug	2
36	22T1 – 016	rubber plug	1
37	029100003	Needle plate	1
38	22T1 – 020	Needle plate screw	2
39	22T1 – 021G1	Slide plate	1
40	22T1 – 021G2	Spring for slide plate	1
41	22T1 – 021G3	screw	2
42	48T1 – 005	Leg	3
43	GB93 – 87	Washer	3
44	22T1 – 017	Rubber plug	1
45	22T1 – 008	Screw	2
46	22T8 – 009	Screw	2

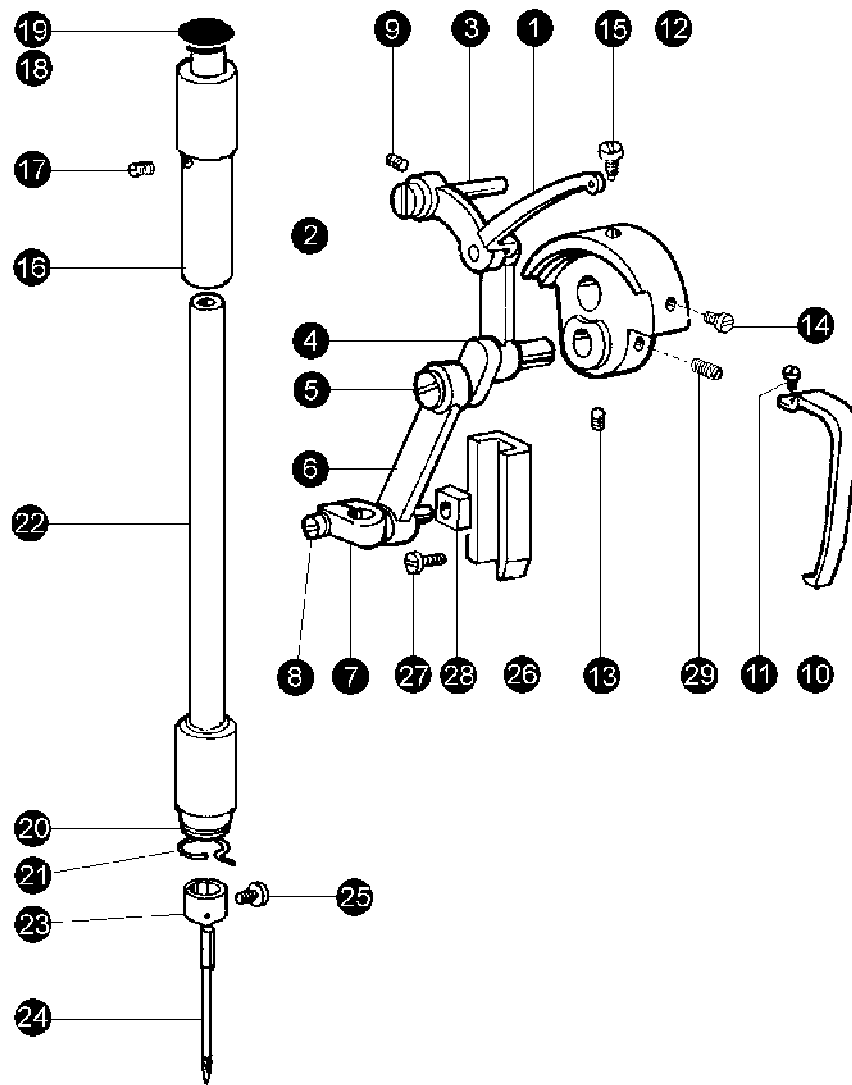

2. NEEDLE BAR AND THREAD TAKE – UP MECHANISM

No.	Ref. No.	Description	Qt.
1	22T2 – 001A1a	Thread take – up lever	1
2	22T2 – 001A2	Thread take – up link	1
3	22T2 – 001A3	Thread take – up lever hinge pin	1
4	029211000	Thread take – up crank	1
	22T2 – 001A5	Needle roller bearing	2
5	22T2 – 001A6	Set screw (left hand thread.)	1
6	22T2 – 001A7b	Needle bar link ass	1
7	22T2 – 001A8	Needle bar connecting bar joint	1
8	22T2 – 001A9	Screw	1
9	22T2 – 002	Screw	1
10	36T2 – 007	Take – up lever guard	1
11	22T2 – 004	Screw	1
12	029200001	Needle bar crank	1
13	22T2 – 005B2	Screw	1
14	22T2 – 006	Screw	1
15	22T2 – 007	Needle bar position screw	1
16	22T2 – 008	Needle bar bushing(upper)	1
17	22T2 – 009	Set screw	1
18	22T2 – 010	Felt piug	1
19	22T2 – 011	Rubber plug	1
20	22T2 – 012C1	Needle bar bushing(lower)	1
21	22T2 – 012C2	Thread guide for needle bar bushing	1
22	029200002	Needle bar	1
23	029200003	Thread guide for needle	1
24	22T2 – 016	Needle(DB1)14#	1
25	22T2 – 017	Needle clamp screw	1
26	22T2 – 018	Needle bar connecting link guide	1
27	22T2 – 019	Set screw	2
28	22T2 – 020	Slide block	1
29	22T2 – 005B3	Thread take – up crank position screw	1

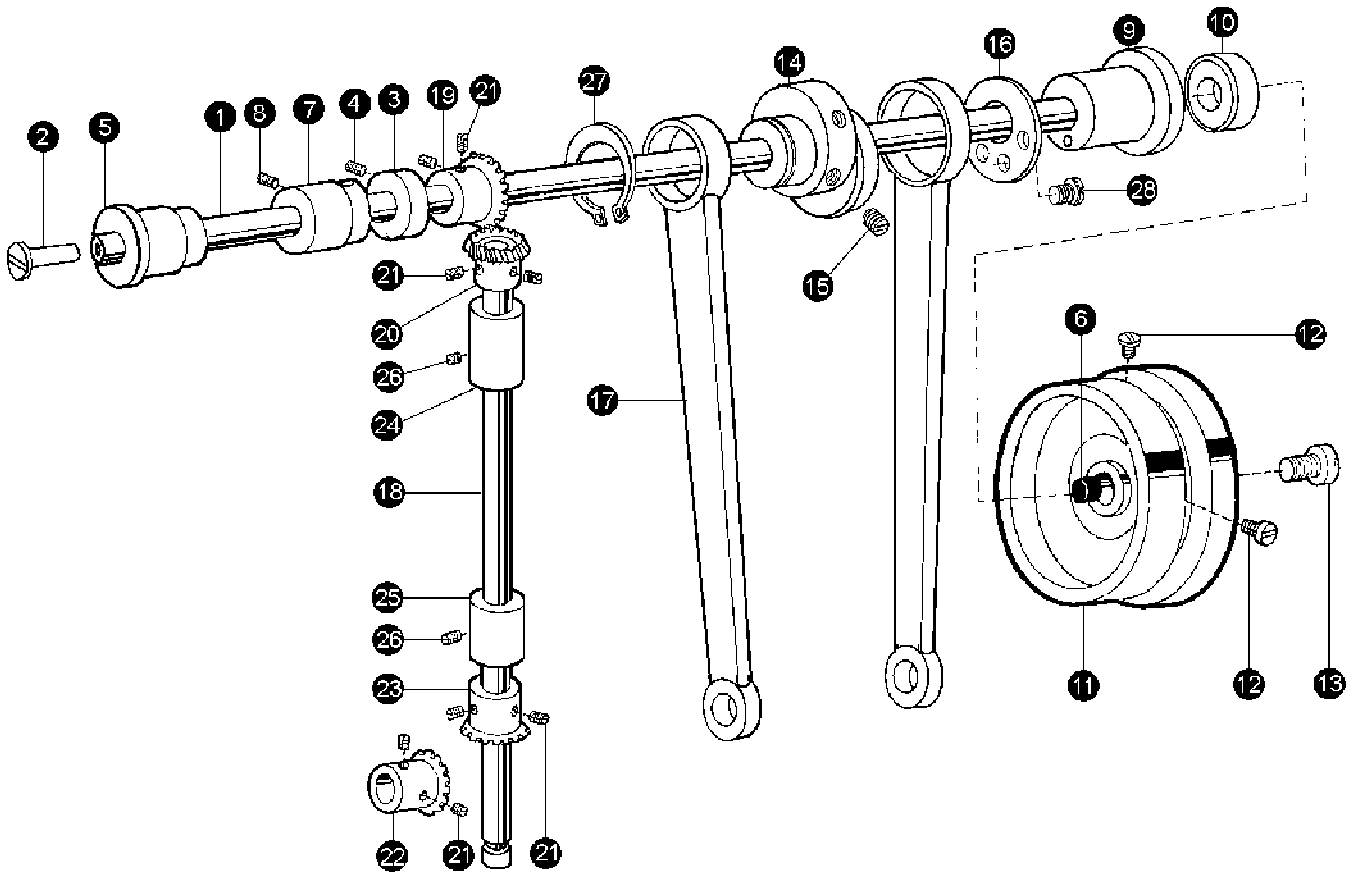

3. ARM SHAFT AND VERTICAL MECHANISM

No.	Ref. No.	Description	Qty.
1	029300001	Arm shaft	1
2	124T3 - 001A2	Adjusting screw	1
3	22T3 - 002B1	Collar for arm shaft	1
4	22T3 - 002B2	Set screw	2
5	22T2 - 003	Arm shaft bushing (left)	1
6	22T3 - 001A2	Oil felt	1
7	22T3 - 004	Arm shaft bushing (Middle)	1
8	22T2 - 002	Set screw	1
9	124T3 - 003C1	Arm shaft bushing (right)	1
10	124T3 - 003C2	Oil seal	1
11	153310001	Balance wheel	1
12	22T3 - 007C2	Set screw	2
13	22T3 - 008	Set screw	1
14	38T3 - 003	Eccentric wheel	1
15	22T1 - 013	Eccentric wheel screw	2
16	38T3 - 004	Spacer	1
17	22T3 - 009D1c	Crank rod for lifting rock shaft	1
18	22T3 - 010E1	Vertical shaft	1
19	22T3 - 010E2a1 - 2	Bevel gear for arm shaft	1
20	22T3 - 010E2a2 - 2	Bevel gear for vertical shaft (upper)	1
21	22T2 - 005B3	Set screw	8
22	22T3 - 010E2b1 - 2	Bevel gear for hook shaft	1
23	22T3 - 010E2b2 - 2	Bevel gear for Vertical shaft (lower)	1
24	22T3 - 011	Vertical shaft bushing (upper)	1
25	22T3 - 011	Vertical shaft bushing (lower)	1
26	22T2 - 002	Set screw	2
27	38T3 - 004	Spacer	1
28	100T6 - 012	Screw	3

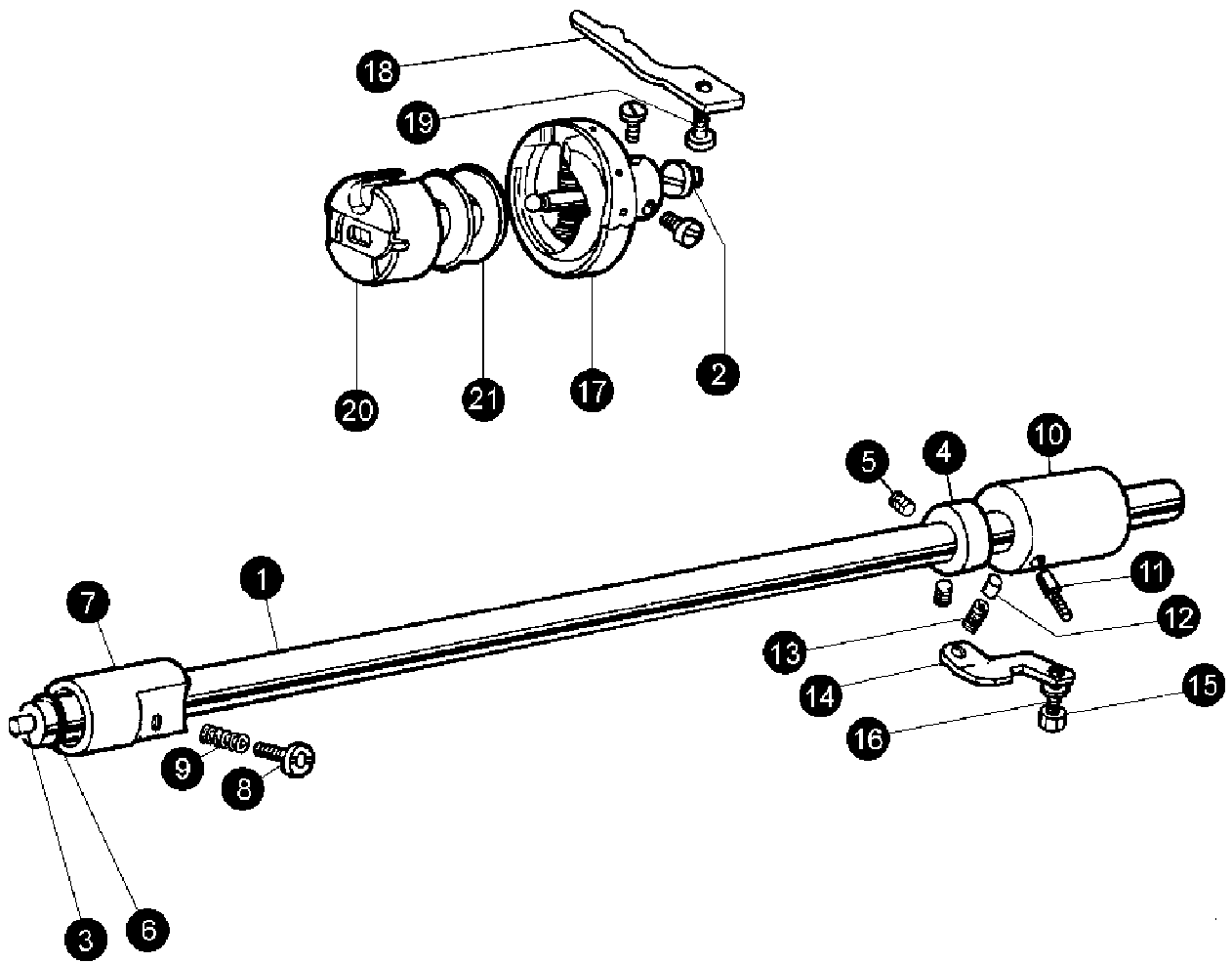

4. ROTATING HOOK MECHNISM

No.	Ref. No.	Description	Qty.
1	22T4 - 001A1	Rotating hook shaft	1
2	22T4 - 001A1a1	Filter screw	1
3	22T4 - 001A1a2	Filter	1
4	22T4 - 002B1	Collar for rotating shaft	1
5	22T2 - 009	Set screw	2
6	38T4 - 009G	Oil seal for rotating	1
7	38T4 - 010	Rotating hook shaft bushing (left)	1
8	22T4 - 005	Oil adjusting screw	1
9	22T4 - 006	Spring for oil adjuster	1
10	38T4 - 014F1	Rotating hook shaft bushing (right)	1
11	22T4 - 007C2	Oil pipe for hook shaft bushing	1
12	38T4 - 015	Plunger	1
13	38T4 - 016	Plunger spring	1
14	22T4 - 010	Guide plate	1
15	22T8 - 009	Screw	1
16	GB93 - 87	Spring washer	1
17	22T4 - 011D	Rotating hook	1
18	22T4 - 013	Rotating hook positioner	2
19	22T4 - 015	Screw	1
20	22T4 - 016F	Bobbin case	1
21	38T4 - 006	Bobbin	1

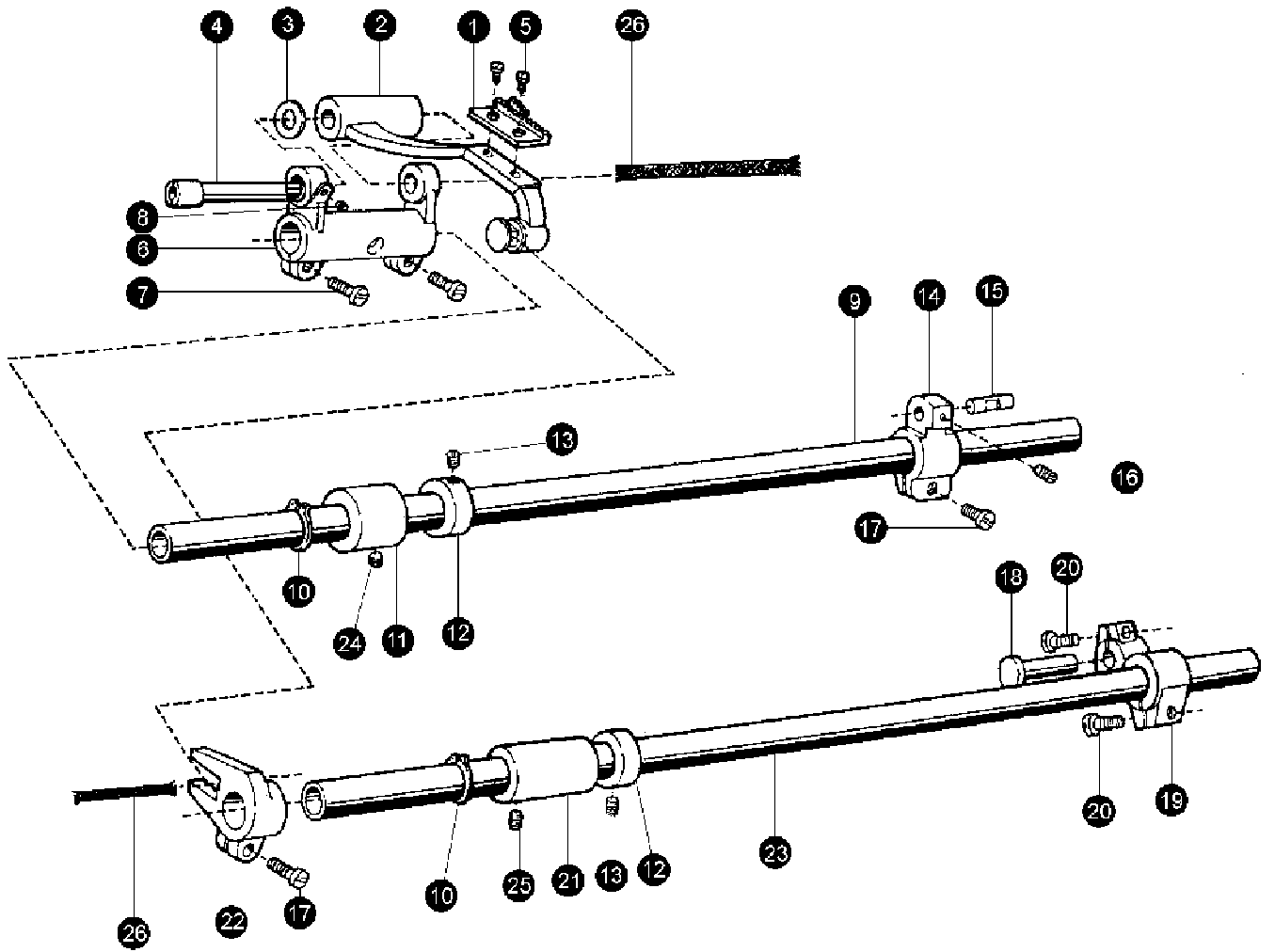

5. FEEDING AND FEED LIFTING MECHANISM

No.	Ref. No.	Description	Qt.
1	029600001	Feed dog	1
2	36T4 - 001A1a	Feed bar	1
3	22T6 - 001A6	Washer	1
4	36T4 - 001A2	Feed bracket shaft	1
5	22T6 - 001A4	Screw	2
6	22T6 - 001A1a	Feed rock bracket shaft arm	1
7	22T6 - 001A1b	Screw	2
8	22T2 - 019	Screw	1
9	124T6 - 002	Feed rock shaft	1
10	GB894. 1 - 86	C - type stop ring	2
11	124T6 - 001	Feed rock shaft bushing	1
12	22T6 - 005B1	Collar	2
13	22T3 - 002B2	Set screw	4
14	36T4 - 003	Feed rock shaft crank(right)	1
15	36T4 - 004H01	Feed link stop	1
16	36T5 - 008E5	Set screw	1
17	22T6 - 008D3	Screw	2
18	22T6 - 007	Hinge	1
19	36T4 - 017	Feed lifting shaft crank(right)	1
20	22T6 - 016	Screw	2
21	22T6 - 012	Bushing for feed lifting shaft	1
22	36T4 - 018H1D1	Feed lifting shaft crank	1
23	124T6 - 003	Feed lifting rock shaft	1
24	22T2 - 009	Set screw	1
25	22T2 - 002	Set screw	1
26	36T4 - 001A3	Wick	2

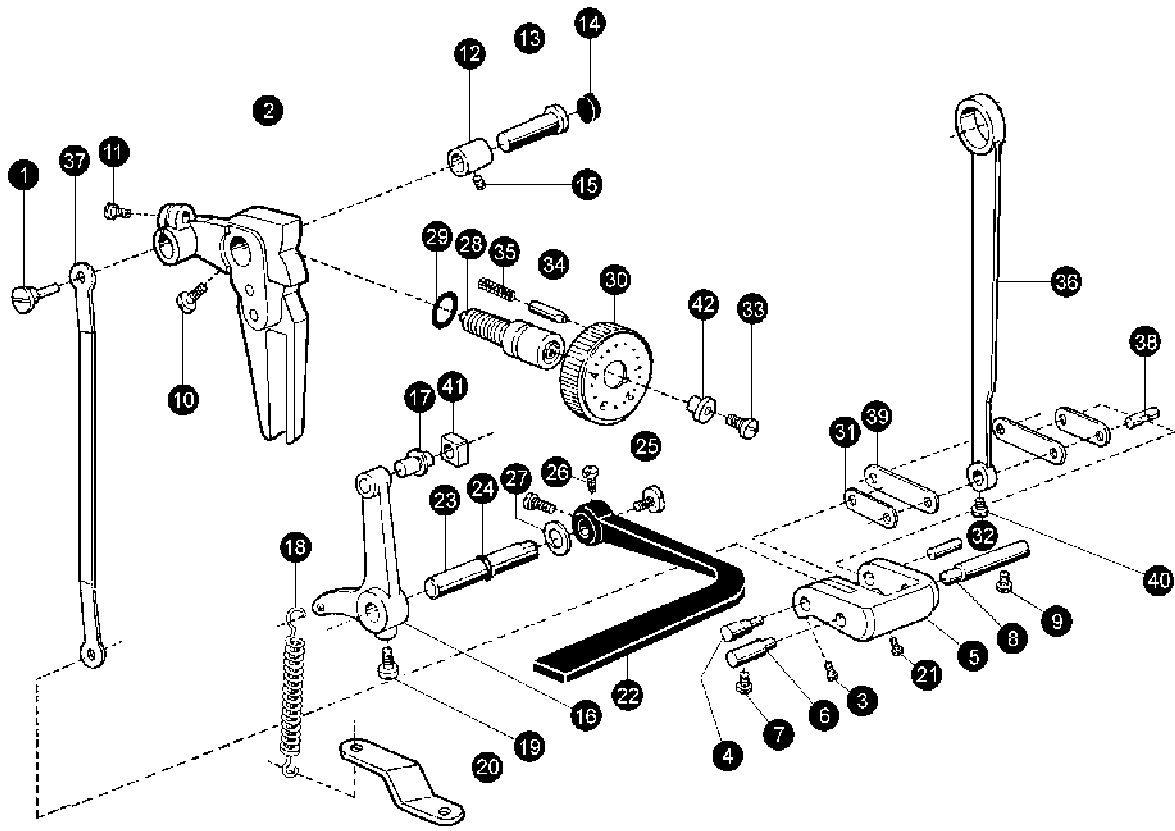

6. STITCH LENGTH REGULATING MECHANISM

No.	Ref. No.	Description	Qty.
1	38T5 - 001	Connecting stud	1
2	57T5 - 001	Feed regulator	1
3	38T5 - 008E8	Screw	1
4	38T5 - 008E9	Lever link eccentric shaft	1
5	38T5 - 008E10	Lever regulator	1
6	38T5 - 009H02	Pin (left)	1
7	22T6 - 008D3	Screw	1
8	38T5 - 009H01	Pin (right)	1
9	22T6 - 008D3	Screw	1
10	22T5 - 010D4	Screw of feed regulator	1
11	22T2 - 019	Screw	1
12	22T5 - 003	Feed regulator bushing	1
13	22T5 - 004	Feed regulator shaft	1
14	38T5 - 003	Rubber plug (Ø20)	1
15	22T2 - 002	Set screw	1
16	22T5 - 012E1	Back tacking crank	1
17	22T5 - 012E1a1	Slide block pin	1
18	22T5 - 012E2	Lever spring	1
19	22T5 - 013	Set screw	1
20	22T5 - 014	Bracket for spring	1
21	38T5 - 008E7	Screw	1
22	22T5 - 010D1	Backtacking lever	1
23	38T5 - 006C1a1	Backtacking lever shaft	1
24	GB3452. 1 - 92	O - ring	1
25	22T5 - 010D3	Screw	1
26	22T5 - 010D4	Screw	2
27	22T5 - 011	Washer	1
28	124T5 - 001A2	Feed regulator screw	1
29	124T5 - 001A3	O - ring	1
30	027500001	Knob	1
31	38T5 - 008E4H01	Feed rock link	2
32	38T5 - 008E6	Pin	1
33	38T5 - 007D5	Screw	1
34	22T5 - 008	Stopper pin	1
35	22T5 - 009	Spring for stopper pin	1
36	38T5 - 008E2	Lever feed connecting rod	1
37	38T5 - 008E3	Feed regulator link	1
38	38T4 - 004H02	Sink shaft	1
39	38T5 - 008E4H02	Feed rock arm link	2
40	38T5 - 008E5	Screw	1
41	22T5 - 012E1a2	Crank slide block	1
42	38T5 - 007D4	Bushing	1

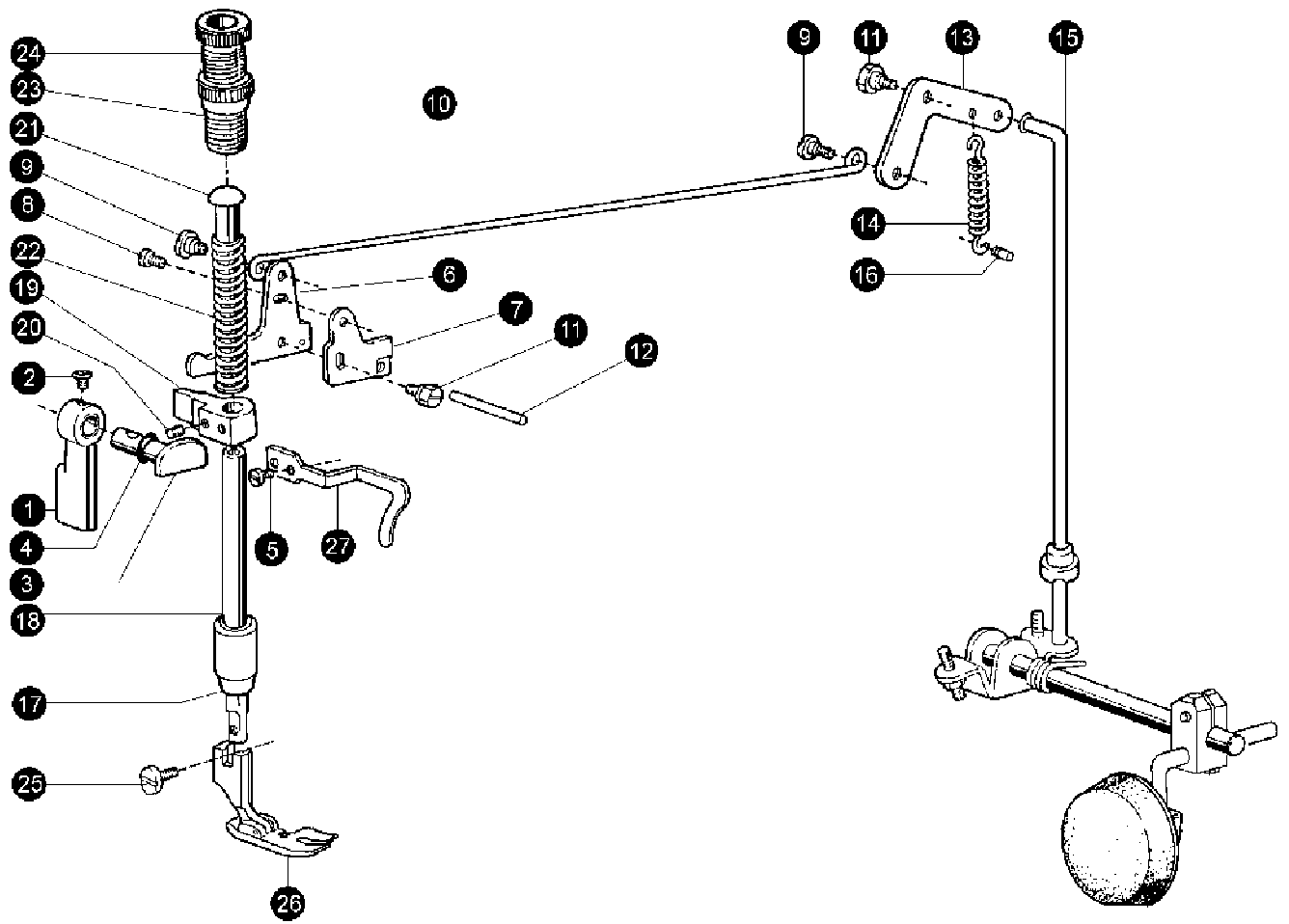

7. PRESSER FOOT MECHANISM

No.	Ref. No.	Description	Qt.
1	38T6 -001A1	Presser bar lifter	1
2	58T6 -001A1a6	Set screw	1
3	38T6 -002B1	Eccentric wheel for presser bar	1
4	GB3452.1 -92	Oil seal for presser bar	1
5	22T2 -004	Screw	1
6	38T6 -003C1a1	Knee lifter lever (left)	1
7	22T7 -004B1b	Tension releasing cam	1
8	22T7 -004B1c	Screw	1
9	22T7 -004B2	Hinge screw	2
10	22T7 -004B3	Knee lifter rod	1
11	22T7 -005	Bolt for tension releasing cam	2
12	22T7 -006	Tension releasing pin	1
13	22T7 -007C1	Knee lift lever (right)	1
14	22T7 -007C2	Spring for knee lift lever(right)	1
15	22T7 -007C3	Knee lifter connecting rod	1
16	22T7 -008	Pin for spring	1
17	22T7 -009	Presser bar bushing	1
18	029700001	Presser bar	1
19	22T7 -011D1	Presser bar lifting bracket	1
20	22T1 -013	Set screw	1
21	22T7 -012	Presser bar guide	1
22	22T7 -013	Presser spring	1
23	22T7 -014E1	presser regulating thumb screw	1
24	22T7 -014E2	Lock nut	1
25	58T1 -022	Presser foot screw	1
26	029702000	Presser foot complet	1
27	38T6 -009	Slack thread regulator	1

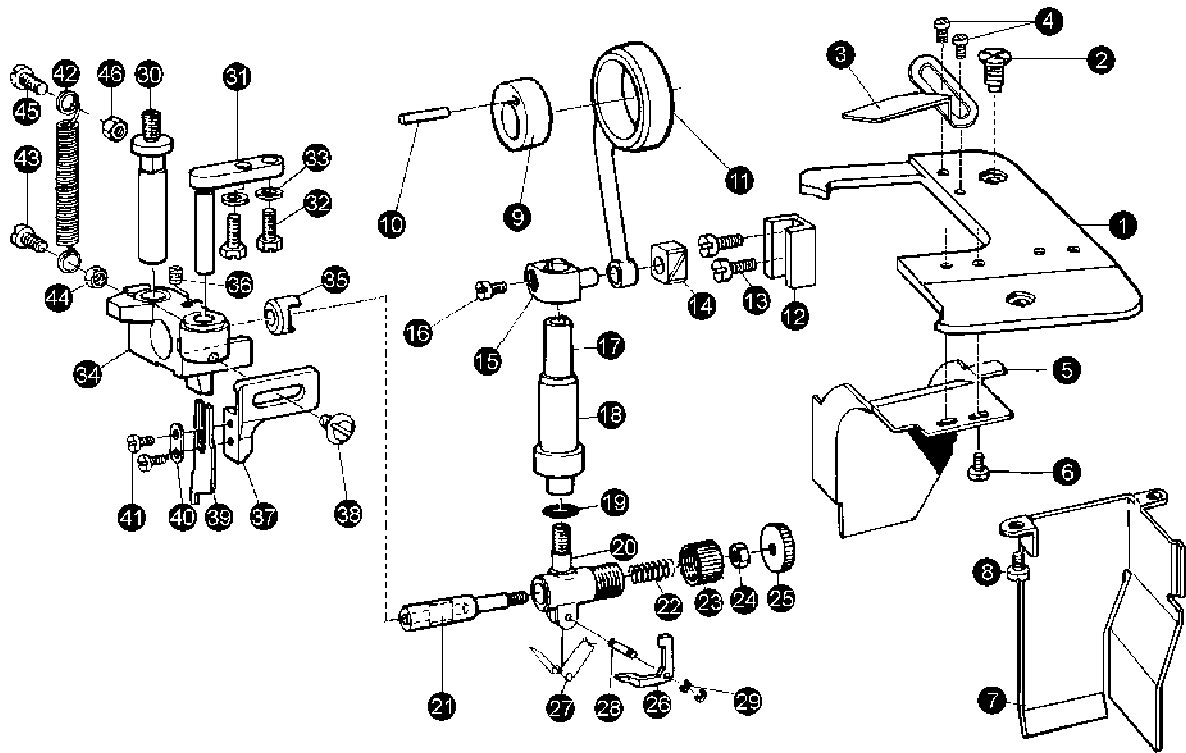

8. KNIFE COMPONTS

No.	Ref. No.	Description	Qt.
1	029800001	Throat plate	1
2	22T1 - 020	Screw	2
3	029800002	Waste material guide	1
4	22T8 - 011C4	Screw	2
5	029800003	Waste material chute	1
6	28T3 - 034	Screw	2
7	029800005	Waste material guard	1
8	22T2 - 001A9	Screw	2
9	029800006	Knife driving eccentric cam	1
10	GB119 - 86	Knife driving eccentric cam pin	1
11	029800007	Knife driving rod	1
12	029800008	Slide block guide	1
13	22T2 - 019	Screw	2
14	22T9 - 020	Crank slide block	1
15	029800009	Knife driving stud connection asm	1
16	36T5 - 008E8	Screw	1
17	029800010	Knife driving stud	1
18	029800011	Bushing	1
19	GB3452. 1 - 92	Rubber ring	1
20	029800012	Knife driving rod clutch retainer	1
21	029800013	Knife driving rod clutch pin	1
22	029800014	Spring	1
23	029800015	Cap	1
24	28T1 - 035	Nut	1
25	029800016	Knob	1
26	029800017	Knife release lever	1
27	029800018	Spring	1
28	029800019	Pin	1
29	GB896 - 86	Snap ring	2
30	029800020	Knife driving block stud	1
31	029800021	Guide stud for knife driving block	1
32	GB29. 1 - 88	Bolt	2
33	22T1 - 007	Washer	2
34	029801000	Knife driving block asm	1
35	029801004	Clutch pin bushing	1
36	28T7 - 004	Screw	1
37	029800022	Knife holder	1
38	029800023	Screw	1
39	029800024	Knife	1
40	029800025	Washer	1
41	36T7 - 001A8	Screw	2
42	029800026	Tension spring	1
43	22T1 - 006	Screw	1
44	28T1 - 035	Nut	1
45	22T8 - 009	Screw	1
46	22T9 - 001A10	Nut	1

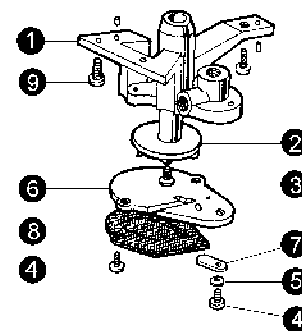
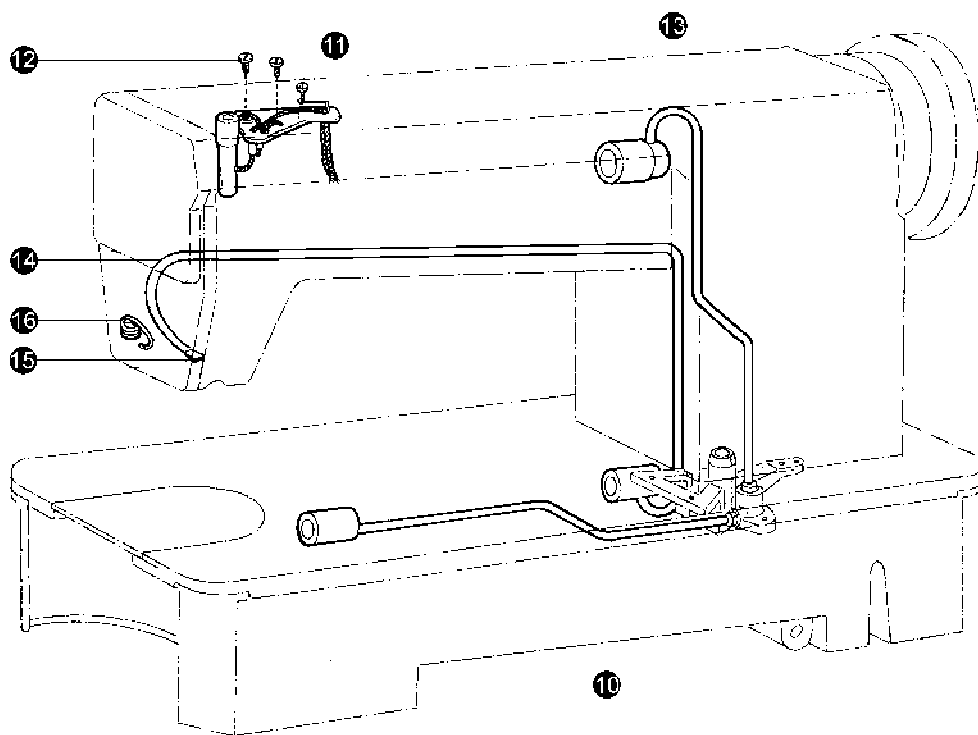

9. LUBRICATION MECHANISM

No.	Ref. No.	Description	Qt.
1	22T8 - 001	Oil pump body	1
2	22T8 - 002	Oil pump impeller	1
3	22T8 - 003	Screw	1
4	22T8 - 004	Screw	3
5	GB93 - 87	Spring washer	1
6	22T8 - 008	Oil pump fitting plate	1
7	22T8 - 007	Oil adjusting plate	1
8	22T8 - 008A	Oil pump screen complete	1
9	22T8 - 009	Screw	3
10	36T10 - 001A	Oil pipe for hook shaft	1
11	029910000	Oil braid fitting plate	1
12	22T7 - 015	Screw	2
13	22T8 - 013D	Oil pipe for arm shaft	1
14	22T8 - 014	Oil returning pipe	1
15	22T8 - 015	Felt pouch for return oil filter	1
16	36T10 - 002	Oil returning pipe holder	1

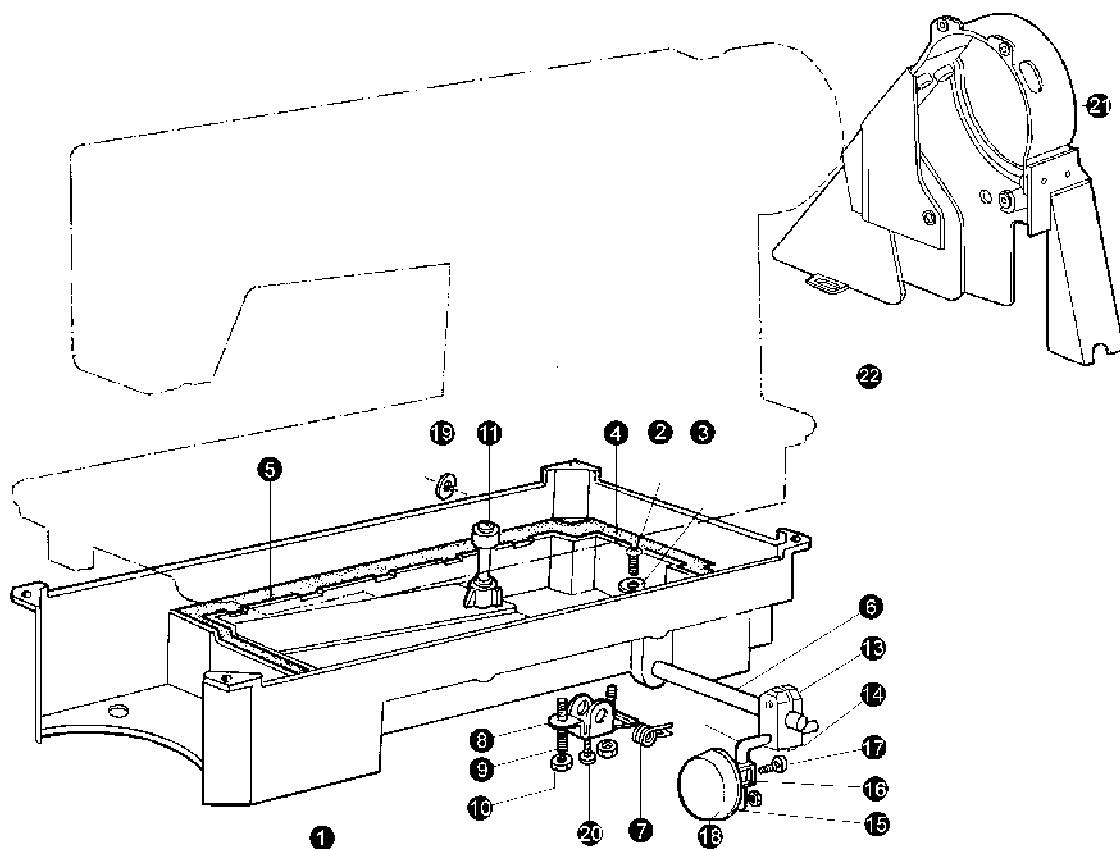

10. OIL RESERVOIR AND OTHER ACCESSORIES

No.	Ref. No.	Description	Qty.
1	029F00001	Oil reservoir	1
2	22T9 - 001A2	Oil drain screw	1
3	22T9 - 001A3	Washer	1
4	22T9 - 001A4	Gasket for oil reservoir (S)	1
5	22T9 - 001A5	Gasket for oil reservoir (B)	1
6	22T9 - 001A6	Hinge pin for knee lifter lever	1
7	22T9 - 001A7	Back spring for knee lifter	1
8	22T9 - 001A8	Knee lifter stop bracket	1
9	22T9 - 001A9	Adjusting screw	2
10	22T9 - 001A10	Lock nut	2
11	22T9 - 003B1	Knee lifter lifting rod	1
12	22T9 - 003B2	Knee lifter bell crank	1
13	22T9 - 003B3	Knee lifter bell crank joint	1
14	GB5781 - 86	Set screw	2
15	22T9 - 003B5	Knee lifter plate	1
16	22T9 - 003B6	Bracket for knee lifter plate	1
17	22T9 - 003B7	Set screw	1
18	22T9 - 003B8	Pat for knee lifter plate	1
19	GB896 - 86	C - type stop ring	1
20	22T9 - 036	Screw	1
21	124T9 - 003B	Belt cover	1
22	124T9 - 004C	Belt cover(S)	1

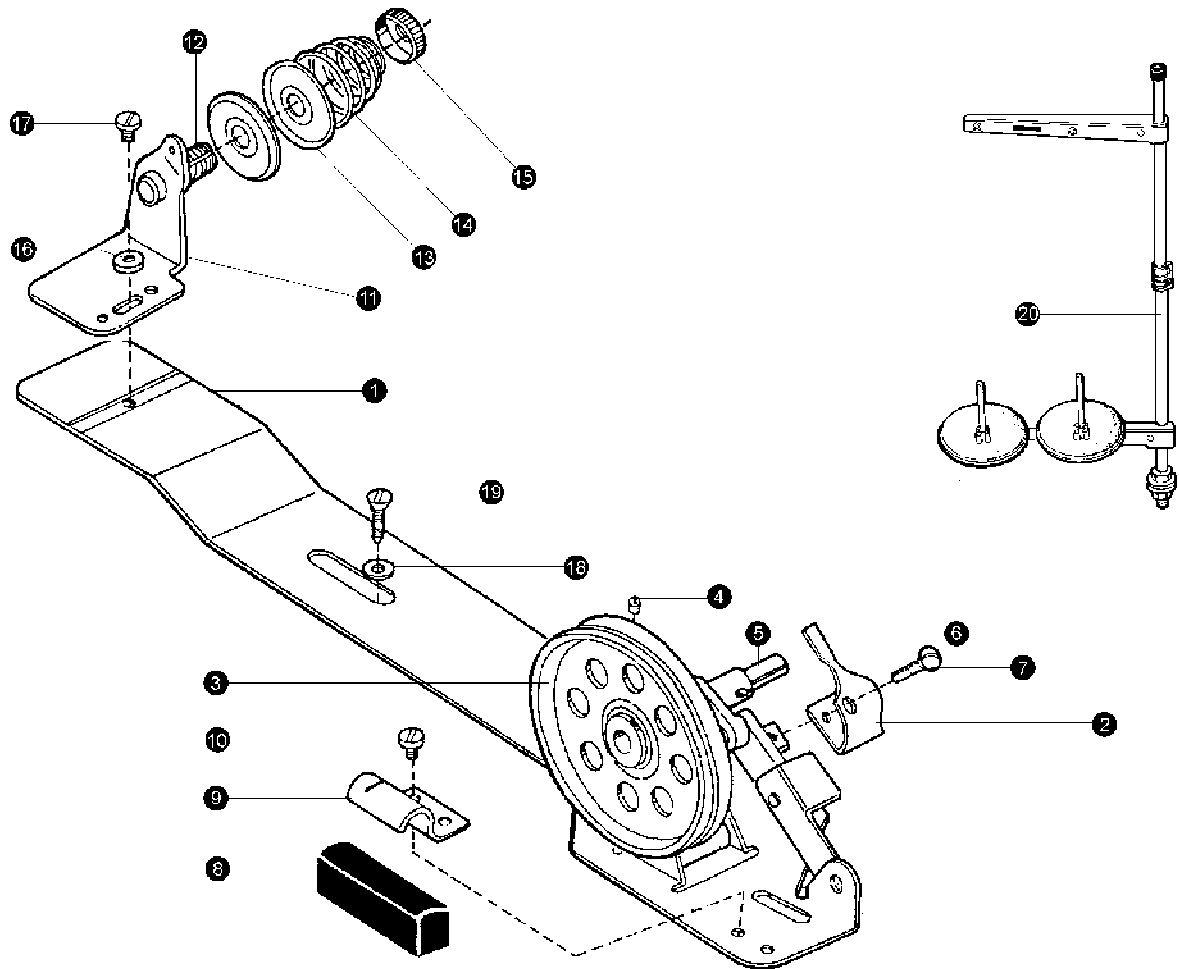

11. BOBBIN WINDER、SPOOL STAND MECHANISM

No.	Ref. No.	Description	Qty.
1	6F0-001A	Bobbin winder base	1
2	6F0-001A6a	Bobbin winder stop latelever set	1
3	6F0-002	Bobbin winder pulley	1
4	01/B112	Screw	1
5	6F0-003	Bobbin winder spindle	1
6	6F0-004-1	Bobbin winder stop latch	1
7	6F0-005	Adjusting screw	1
8	6F0-006	Stopper block	1
9	6F0-007	Stopper block clamp	1
10	6F0-008	Set screw	1
11	6F0-009B1b1	Bobbin winder tension bracket	1
12	17T7-017	Bobbin winder tension stud	1
13	22T1-012F5	Bobbin winder tension discs	2
14	22T1-012F3	Bobbin winder tension spring	1
15	J2. 2. 7	Tension stud nut	1
16	BQ10021	Washer	1
17	22T2-004	Tension bracket screw	1
18	GB848-85	Washer	2
19	GB99-86	Wood screw	2
20	GXJ-2	Spool stand	1

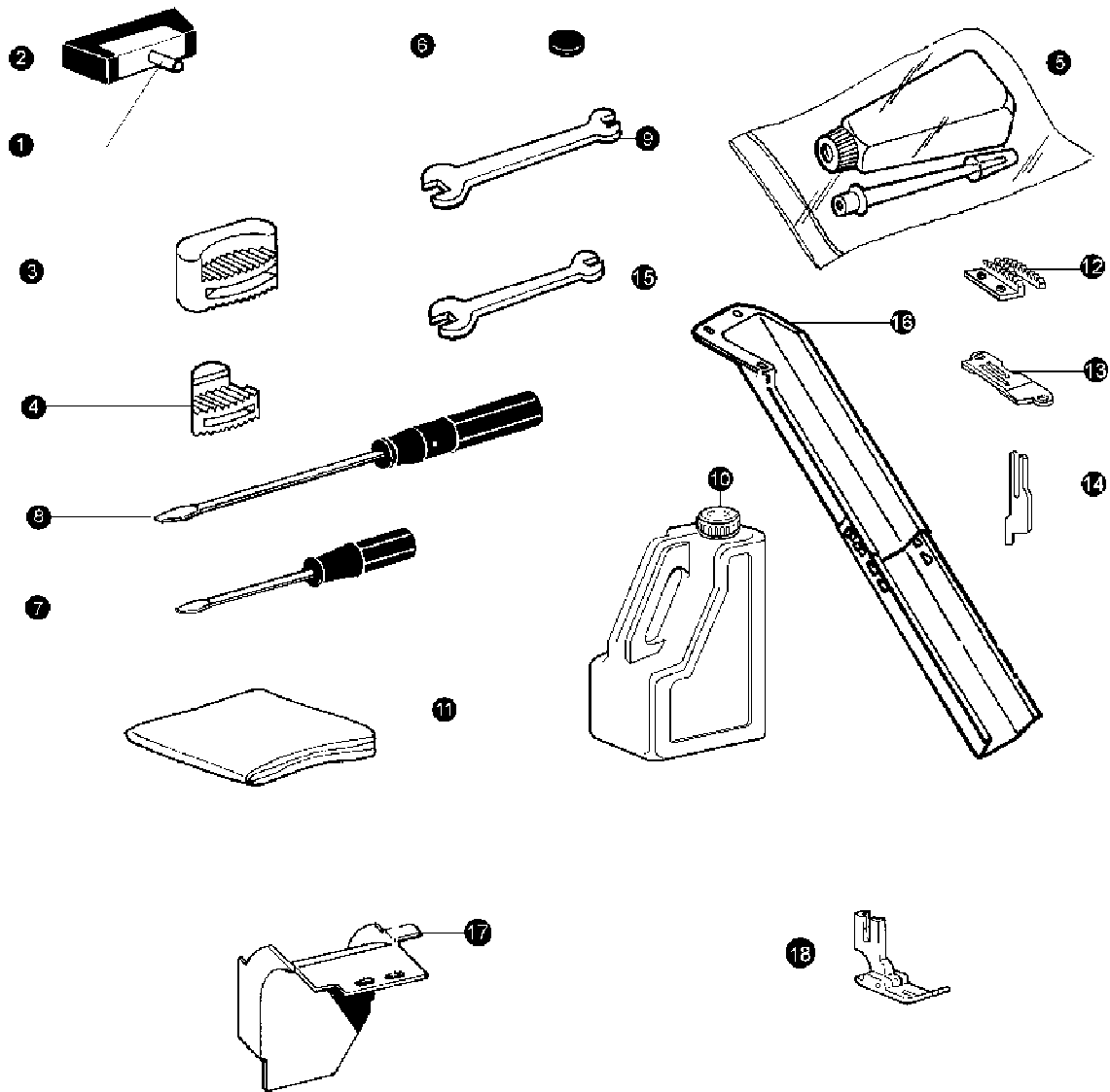

12. ACCESSORIES

No.	Ref. No.	Description	Qty.
1	22T9 - 007F1	Hinge of machine head	2
2	22T9 - 007F2	Hinge socket of machine	2
3	22T9 - 009	Rubber cap (B)	2
4	22T9 - 010	Rubber cap (S)	2
5	22T9 - 011	Oil pot	1
6	22T9 - 012	Magnet	1
7	22T9 - 013	Screw driver (B)	1
8	22T9 - 015	Screw driver (S)	1
9	22T9 - 016	Double end wrench (B)	1
10	22T9 - 017	Oil can	1
11	22T9 - 018	Vinyl couer	1
12	029800002	Feed doy	1
13	029100005	Needle plate	1
14	029800021	Knife	1
15		Double end wrench (S)	1
16	029F00002	Waste material chute	1
17	029800004	Material guide	1
18	22T7 - 017F	Press foot complete	1

GC6170 high speed look stitch sewing machine
with vertical edge trimmer's Main technical data

Application		Plain seaming
Sewing speed (S. P. M.)		4500 (S. P. M.)
Max. stitch length(mm)		4 (mm)
Presser foot lift (mm)	By hand	5 (mm)
	By knee	8 (mm)
Needle		DB x1 11#—14#
Rotating hook's Lubrication		automatic Lubrication
Trim edge width (mm)		Normal 3.2 (mm)
		special 2.4 4.0 4.8 6.4 9.5 (mm)
Motor		Sewing machine motor(370W)

- Besides adjusting stitch, please laypeople don't debug or maintain machine.
- Parts are subject to changes in design without prior notice.

XI'AN TYPICAL INDUSTRIES CO., LTD.

Add: No. 1 Taibai South Road,
Xi'an, P. R. China - 710069
Tel : +86 -29 - 8279091 8279150
Fax : +86 -29 - 8249715 8245215
E-mail: typical@chinatypical.com
Http: www.chinatypical.com
Http: www.globalsources.com

2003. 02. 23 ©